

UN-CURBED ROADWAY

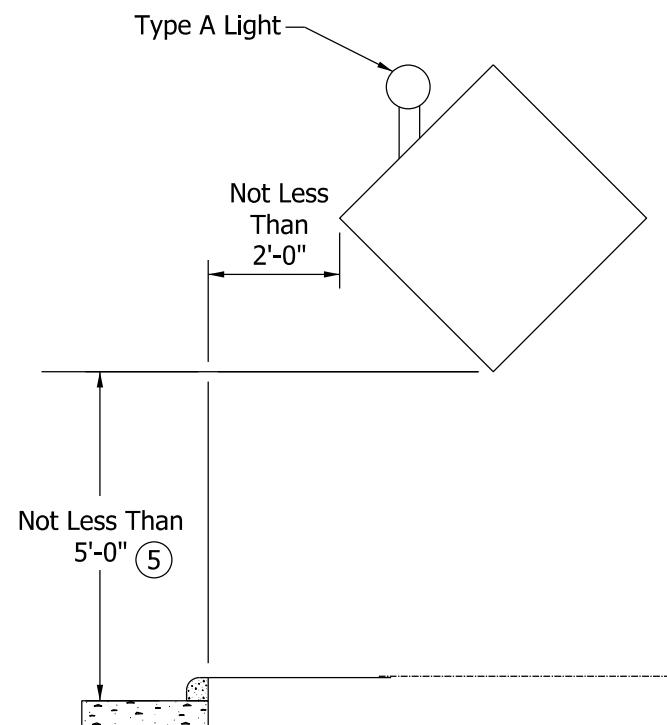

CURBED ROADWAY

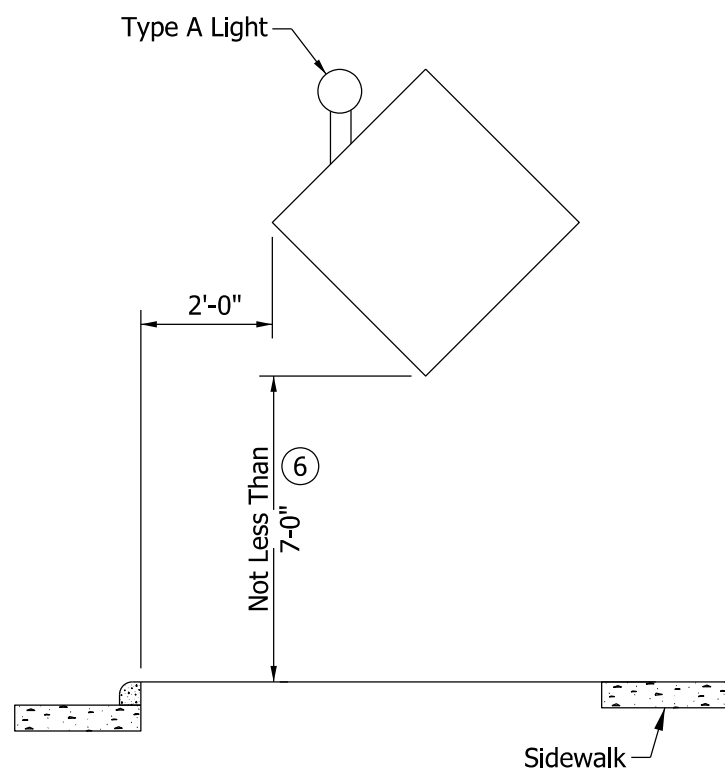
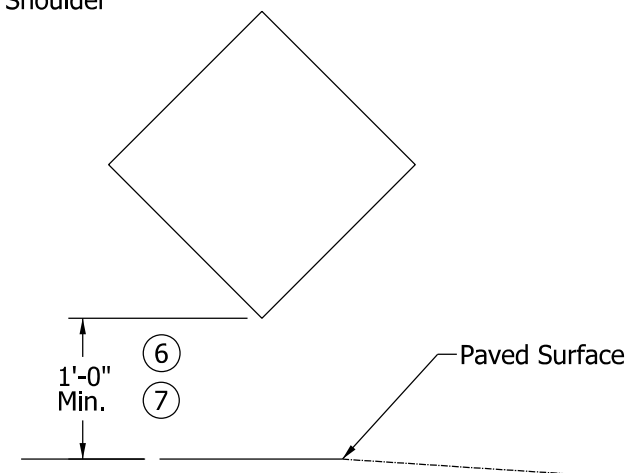

TEMPORARY MOUNTED CONSTRUCTION SIGN

NOTES:

1. See Standard Drawing E 801-TCSN-01 for additional notes.
2. Signs, lights, and supports shall satisfy NCHRP 350 or MASH crash evaluation criteria.
- ③ An advisory speed plaque, required to be placed with another construction sign, may be mounted on the post closest to the roadway at a height not less than 4 ft above the edge of pavement adjacent to the sign. The bottom of the construction warning sign shall not be lower than the top of the advisory speed plaque.
4. Type A warning light required on all construction signs.
- ⑤ In urban area or on Interstate route, mounting height shall not be less than 7 ft.
- ⑥ When signs are placed on sidewalk, a 4 ft useable width must be maintained. No part of the sign or support that is less than 7 ft in height may protrude more than 4 in. into the 4 ft useable sidewalk width.
- ⑦ Temporary mounted construction signs for nighttime work or for operations which affect traffic lanes shall be mounted on portable supports that have a minimum sign mounting height of 5 ft above the traveled way. On roadways where on-street parking is allowed, temporary mounted construction signs shall have a minimum sign mounting height of 7 ft above the traveled way.

INDIANA DEPARTMENT OF TRANSPORTATION

TEMPORARY MOUNTED CONSTRUCTION SIGNS